

Anthony Conventional AC Series Liftgates®



With Lifetime Adaptor Frame
Warranty Against Rotational Wear

Lifting Capacities: 1,600 lb. 2,000lb. 2,500 lb.

Ideal for platform stake bodies and utility bodies. Works with either roll-up or swing type doors.



ANTHONY
LIFTGATES, INC.®

Available Models, Platforms and Capacities

Model	Lifting Capacity (lbs.)	Bed Height Min-Max	Platform Load Area and Ramp	Approx. Shipping Wt. (lbs.)
AC-1600-SF	1,600	36"-57"	72" x 36"+6"	776
AC-1600-SF	1,600	36"-57"	84" x 36"+6"	792
AC-1600-SF	1,600	36"-57"	90" x 36"+6"	808
AC-2000-SF	2,000	36"-57"	72" x 36"+6"	768
AC-2000-SF	2,000	36"-57"	84" x 36"+6"	802
AC-2000-SF	2,000	36"-57"	90" x 36"+6"	818
AC-2500-SF	2,500	36"-57"	72" x 36"+6"	798
AC-2500-SF	2,500	36"-57"	84" x 36"+6"	814
AC-2500-SF	2,500	36"-57"	90" x 36"+6"	830

All specifications subject to change without notice.

Standard Features and Specifications

- Spring counterbalanced platform design for easy and reliable opening & closing of platform – manual
- Special "Service-Free" bushings at major wear points; no grease zerks to service
- Low-pour hydraulic fluid for better cold weather performance
- Toggle switch control, stationary mount
- Lockable steel power pack enclosure
- Diamond tread platform surface
- Circuit breaker – 150 Amp.
- Silicone sealed heat shrink electrical connections
- Pressure compensated flow control valve
- Chrome plated piston rod
- 12 volt DC/hydraulic drive
- Meets TMC recommended practices
- Powder coated finish
- Yellow Di-chromate plated pins used at all pivot points
- Pressure compensated flow valve to provide constant and controlled lowering speed
- Relief valve prevents overloading during lifting cycle
- Piston cylinder wear rings to prevent scoring
- Adjustable packing gland nut on cylinder allows adjustment of piston rod seal
- EZ Mount installation, hydraulics are factory assembled, must attach platform
- Latch pin assembly to hold gate securely in closed position
- 2+1 warranty – 2 years on mechanical components, 1 year on hydraulic system, parts and labor
- Low operating pressure extends service life of power unit, hoses, cylinder seals, and battery
- ZLC™ zero leak concept – uses machined fittings, SAE "O" rings, and JIC hydraulic connections

Options

- Hand-held control (on coiled cord) with plug and socket
- Cab cut-off switch (recommended option) or ignition cut-off solenoid
- 5 ton pintle hook bracket (42" bed height minimum)
- Expanded metal platform
- Custom platforms and applications
- Platform coating with Wing Walk compound
- 42" deep + 6" ramp platform

Mounting Requirements

A Bed Height Adapter Frame	B Bed to top of Clearance	C Mounting Plate
36" - 41"	15 3/4"	35 1/2"
42" - 49"	19"	30 3/4"
50" - 51"	20"	30 1/4"
52" - 53"	21"	29 3/4"
54" - 55"	22"	29 1/8"
56" - 57"	23"	29"

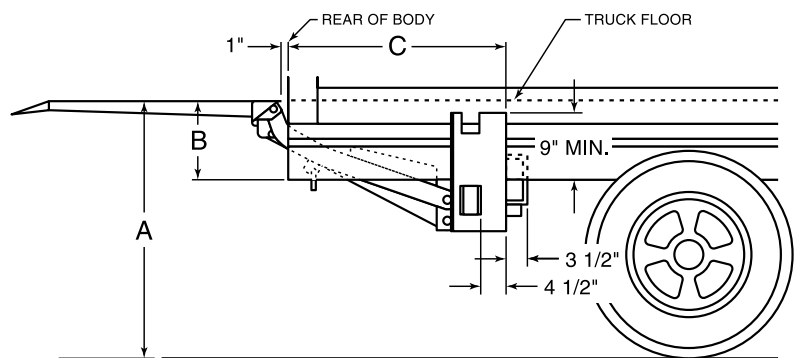

ANTHONY
LIFTGATES, INC.®

Anthony Liftgates, Inc.
1037 W. Howard Street
P.O. Box 615
Pontiac, IL 61764-0615
Phone: 815.842.3383
Fax: 815.844.3612
Toll Free: 800.482.0003
www.anthonyliftgates.com

Available At:
Cliffside Body Corp.
130 Broad Avenue,
Fairview, NJ 07022
Phone: 201-945-3970
www.CliffsideBody.com