

MBB INTERLIFT

Built to Deliver - Every Time

ILM Medium Duty Rail Lift **1600 - 2000 - 2500 LBS. CAPACITY**



**-OPTIMIZED-
FLEXIBILITY
DURABILITY
PROFITABILITY**

ILM - A straight forward medium duty rail lift. It is simple, compact and easy to install. Now also available with hydraulic close feature.

Design and Construction:

- ◆ Short rails for improved clearance
- ◆ Nylon wear pads on runners
- ◆ Pre-installed power pack wired and filled with multi temp fluid
- ◆ Outside switch shipped loose for optimum placement on truck
- ◆ Optional hydraulic closer can be specified for ease of operation – standard on 60" platform models

Platform:

- ◆ Steel and aluminum platforms are equipped for bill board design
- ◆ 2.5" slim line steel platform
- ◆ Optional aluminum platforms available

Built in Safety Features:

- ◆ Built in cross beam toe deflector
- ◆ 135A circuit breaker together with master disconnect switch

INTERLIFT, Inc .

15939 Piuma Ave., Cerritos, CA 90703

Tel (888) 774 5844

(562) 924 8218

Fax (562) 924 8318

www.interlift.net

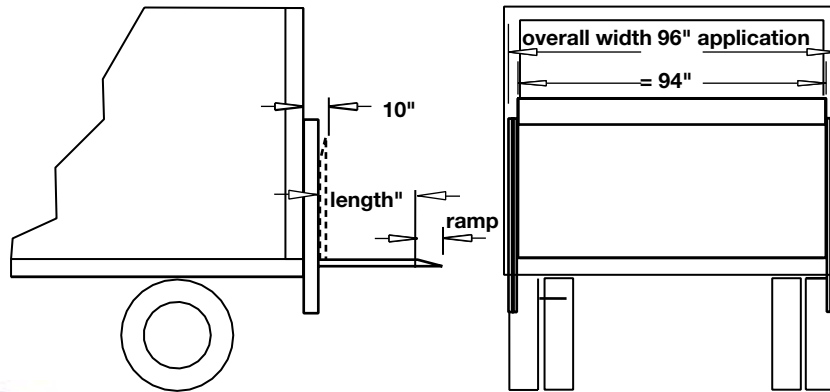

Control system: The side mounted marine type molded switch can be placed for the best operating position depending on the different floor height.

Platform Assist: The ILM platform open and close assist is adjustable and individually tuned at the time of assembly for maximum performance.

Platform configurations: The ILM platform is offered in both steel and aluminum with a variety of different ramp options.

6" fixed, 12" fixed, 12" fixed with cart stop, 12" folding aluminum retention ramp.

Hydraulic Power Fold: Say goodbye to old style mechanical platform folding with our optional hydraulic power fold. This feature takes some of the strain out of the daily operation.

Pump & Motor: The ILM power pack is pre-installed in the cross beam housing for faster installation times. All units are shipped filled with multi-temp hydraulic fluid.

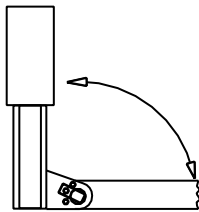

STANDARD FEATURES:

- ◆ Enclosed Power pack
- ◆ Adjustable Platform Chain
- ◆ 135A Circuit Breaker
- ◆ Battery Disconnect Switch
- ◆ Tunable Platform Torsion Bar
- ◆ 2.5" Slimline Steel Platform
- ◆ Bill Board Platform design
- ◆ Nylon Wear Pads on Runners

LIFTGATE OPTIONS:

- ◆ 102" Wide application lifts
- ◆ 12" fixed Ramp in leu of 6" Ramp
- ◆ Hydraulic Power Close
- ◆ 12" Aluminum Retention Ramps
- ◆ Above Floor Models (to max 56")
- ◆ In cab shut off switch
- ◆ Auxiliary Truck Kit
- ◆ Dual Controls
- ◆ Built in Lights
- ◆ 12" Carts Stop ramp
- ◆ Aluminum Platform
- ◆ Custom Platforms

Model	Lifting Capacity (Lbs.)	Platform Size Height (Inches)	Platform Width (Inches)	Ramp Sizes and Style	Bed Height (inches)*	Approx. Weight (Lbs)*
ILM 16	1600	**36, 42 & 60	89" for 96" bodies special widths available	6" and 12" fixed or 12" folding aluminum	*30 to 56	750
ILM 20	2000	**36, 42 & 60				750
ILM 25	2500	**36, 42 & 60				765

* Depending on platform configuration, specifications and the need for unobstructed dock loading

** 36" to 42" platforms are available in steel or aluminum

60" platform is only available in aluminum and incorporates the hydraulic power close feature

Sold By: Cliffside Body Corp. 130 Broad Avenue Fairview, NJ 07022 Phone: 201-945-3970 www.CliffsideBody.com

INTERLIFT, Inc.

Tel (888) 774 5844 - (562) 924 8218

Fax (562) 924 8318