

Anthony ATU Tuckunder SF™

Hydraulic Liftgates®

LIFETIME WARRANTY



Service Free Bushings

With Lifetime Adaptor Frame
Warranty Against Rotational Wear

Lifting Capacities: 1,800 lb. 2,500lb. 3,000 lb. 3,500 lb.



Prepped with
Steel Shot Process



(See page 3)

ANTHONY
LIFTGATES, INC.®

Anthony: Industry Leader

Anthony Liftgates has been the driving force in the industry since 1941, producing innovative designs and quality products for trucks of all sizes. Our factory support is unmatched in the industry, providing dealers and their customers coast to coast with prompt delivery of products, parts orders, and custom engineering requests. Looking for a product you can stake your reputation on? Anthony Liftgates offers a wide range of models backed by the best warranty in the business. For performance, dependability, and value, Anthony delivers the complete package for every application!

Hydraulic System

The **closed hydraulic system** protects against outside contaminants and moisture. The **steel pump enclosure** protects



components from damage by impact, debris, and weather. Hingeless lid design eliminates corroded hinge problems.

LIFETIME WARRANTY Service-Free™ Bushings — An Anthony First

Used at critical pivot points,



these bushings extend pin and arm life, while eliminating routine lubrication and increasing resale value.

Anthony Exclusive, ZLC- Zero Leak Concept™

The use of machined fittings, SAE "O" ring and JIC hydraulic connections, along with factory



installed multi-purpose ATF, mean you'll have long, trouble-free service with no aggravating and costly leaks.

E-Z Mount™ Installation

All Anthony ATU models are factory assembled, tested, and energized to assure the highest quality performance standards. They ship completely assembled on skids for fast, clean, easy installation; and Anthony's pre-



notched center mark template ensures accurate placement of the floor extension and precise spacing for all welds. E-Z Mount installations provide the fastest installation times of any available models.

Positive Electrical Connections

Heat-shrink siliconed wire connections seal out moisture, and



anti-rotation terminals insure rugged circuit protection.

Super Safety Latch –

the most positive in the industry



Low Operating Pressure, Larger-Bore Hydraulic Cylinder

The double-weight hydraulic cylinder allows operation at a lower pressure to increase the



life of the entire hydraulic system, batteries, and electrical components. The extra thick chrome plated piston rod and the piston cylinder wear rings further extend Service-Free operation

Marine-Duty Toggle Switch

Heavy-duty polyethylene switch box with a **potted switch** inside



provide the best all-weather protection available. Terminals and connections are permanently separated and sealed to eliminate corrosion and electrical failure. (Steel switch guard optional)



Quality Standard Features:

Maximum Duty Dual Driver Step Stirrups*

Provide convenient assistance for mounting and dismounting on left or right of truck.

Pressure Compensated Flow Valve

Provides constant and controlled lowering speed of the platform, loaded or unloaded, and prevents platform from "free-fall" under certain hydraulic failures.

Double Plated Chrome Piston Rod

Keeps exposed surface free from rust and contamination to protect seals and extend cylinder life.

Piston Cylinder Wear Rings

Prevent scoring by maintaining piston/cylinder wall tolerances.

Relief Valve

Prevents overloading during lifting cycle.

Low Operating Pressure

Extends service life of power unit, hoses, cylinder seals and battery.

3/16" Formed Diamond Tread Floor Extension

Provides rugged and attractive surface.

1/8" Industrial Diamond Tread Platform

With the largest standard platform in the industry.

Platform Roller Wheel Opener

Prevents metal-on-metal damage and provides smooth folding and unfolding.

Spring-Assist Platform

Dual torsion springs provide easy opening and closing. Assist springs on flip section. (Single spring on lowboy models.)

Heavy-Duty Sandwiched Hinge Plate

Maintains platform stability under heavy load conditions.



Shot Blast / Powder Coat

All platforms and weldments are prepped with steel shot and then powder coated for a finish that provides the best surface appearance, impact resistance, coating adhesion, and wear resistance.

Proprietary Heat-Treated Adapter Frame Mechanism

Lifetime warranty against rotational wear failure – covers both parts and labor.

Exclusive 3 + 3 Warranty

3 years on mechanical structure, 3 years on electrical / hydraulic systems, parts and labor.

All Anthony Tuckunder liftgates are serial numbered and computer logged for quick factory service identification, warranty and repair information.

Maximum Duty Tubular Steel 2-Step Dock Bumpers

With rubber bumper pads to withstand "dock shock".

Circuit Protection Device (200 Amp.)

Protects truck wiring and power system in the event of a "dead short".

Cab Cut-Off Switch

Ignition cut-off protects liftgate from unauthorized use.

Yellow Di-Chromate Plated Pins

Used at all pivot points, these pins provide long-life protection from rust, road salt, and moisture.



Optional 80" x 45" + 6"
Aluminum Platform model, includes
Power-Down operation



Recessed Toggle Switch
(optional)



Optional 5 & 12 ton
Pintle Hook Brackets



Optional 80" x 48" + 12"
Steel Platform with
Aluminum Retention Ramp

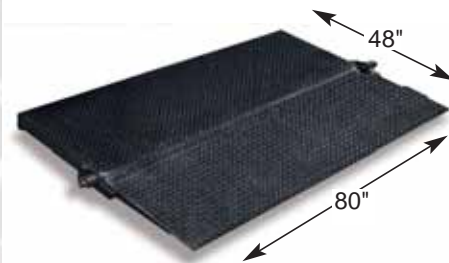

Optional 80" x 48"
steel wedge platform, reinforced
for pallet operations

* NOTICE: Some models of Anthony Liftgates may be provided with step devices to assist the ingress and egress of the truck or trailer rear. These devices are NOT to be considered ALL INCLUSIVE of any requirements or guidelines regarding proper ingress and egress of trucks and trailers. These items are provided as only an added feature for installers to help simplify the meeting of possible ingress and egress requirements. As there are many variables in truck sizes and shapes, it is the installer's responsibility to determine proper ingress and egress requirements, such as steps and hand grips, for each vehicle receiving an Anthony liftgate.

Available Models, Platforms and Capacities

MODEL	Lifting Capacity (lbs.)	Bed Height Min-Max	Platform Load Area and Ramp	Shipping Wt. (lbs.)
ATU-1800-SF	1,800	42"-57"	80" x 45"+6"	953
ATU-2500-SF	2,500	42"-57"	80" x 45"+6"	1025
ATU-3000-SF	3,000	42"-57"	80" x 45"+6"	1070
ATU-3500-SF	3,500	42"-57"	80" x 45"+6"	1073
Power Down Models				
ATU-1800PD-SF	1,800	42"-57"	80" x 45"+6"	953
ATU-2500PD-SF	2,500	42"-57"	80" x 45"+6"	1025
ATU-3000PD-SF	3,000	42"-57"	80" x 45"+6"	1070
ATU-3500PD-SF	3,500	42"-57"	80" x 45"+6"	1073
Aluminum Platform Models with Power Down—Standard				
ATU-1800A-SF	1,800	45"-57"	80" x 45"+6"	766
ATU-2500A-SF	2,500	45"-57"	80" x 45"+6"	791
Lowboy Models				
ATU-1800LB-SF	1,800	36"-57"	80" x 32"+5"	900
ATU-2500LB-SF	2,500	36"-57"	80" x 32"+5"	946

All models shipped with standard ramp ride platform.

Specifications subject to change without notice. Because we constantly strive to improve our products, some current models may vary slightly from photos shown.

Options

- Hand-held control (on coiled cord) with plug and socket
- Third step add-on extension for bumpers
- Street-side control
- Flush-mount control inside van
- Flush-mount toggle switches
- Power down
- Large Wedge Platform — 80" x 48"
- Wireless remote control
- Steel guard for toggle switch control box
- 5 & 12 ton pintle hook brackets
- Custom platforms and applications
- 102" wide floor extension — $\frac{3}{16}$ "
- Lift alert audible alarm
- 80" x 48"+12" steel platform with aluminum retention ramp
- ICC bumper
- $\frac{1}{4}$ " Heavy-duty floor extension for 96" and 102" wide extensions
- LVC - Low Voltage Control, has a programmable security control, cycle counter, and alerts the operator when batteries are running low.



Mounting Requirements

A Bed Height Adapter Frame	B Bed to top of Clearance	C Mounting Plate
36" - 41"	15 $\frac{3}{4}$ "	29"
42" - 49"	19"	24 $\frac{1}{4}$ "
50" - 51"	20"	23 $\frac{3}{4}$ "
52" - 53"	21"	23 $\frac{1}{4}$ "
54" - 55"	22"	22 $\frac{5}{8}$ "
56" - 57"	23"	22 $\frac{1}{2}$ "

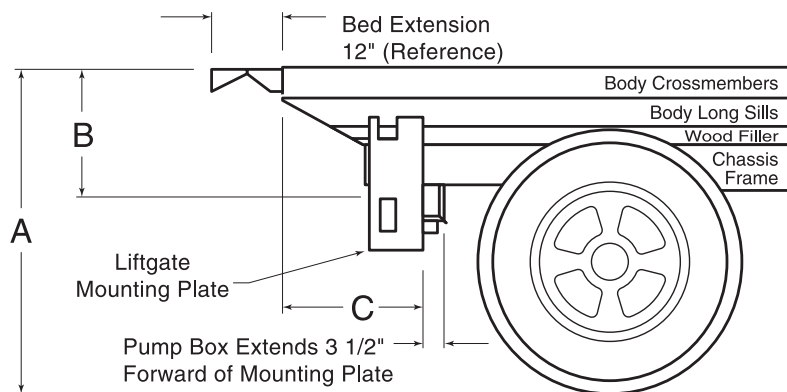

ANTHONY LIFTGATES, INC.®

Anthony Liftgates, Inc.
1037 W. Howard Street
P.O. Box 615
Pontiac, IL 61764-0615
Phone: 815.842.3383
Fax: 815.844.3612
Toll Free: 800.482.0003
www.anthonyliftgates.com

Available At:
Cliffside Body Corp.
130 Broad Avenue,
Fairview, NJ 07022
Phone: 201-945-3970
www.CliffsideBody.com